



QUALITY... PLAIN & SIMPLE®

TH350 Case Mount Shifter Installation Instructions

General Installation Notes:

Please read these instructions completely before beginning the installation. If you have any questions, please call.

Before beginning the installation, disconnect the negative battery cable and use wheel chocks to block the vehicle's wheels.

Make sure the engine, transmission, body and frame are properly grounded.

All Lokar Installation Instructions can be found by visiting www.lokar.com/instructions.html.

Refer to Fig. 1 for the component names.

Tools and Materials Required:

- Standard Allen wrenches: 1/8", 5/32", 3/16", 7/32"
- Wrench or Socket Sizes: 5/16", 3/8", 7/16", 1/2", 9/16", 5/8", 7/8"
- Tape Measure
- Metal cutting tool, such as a hacksaw or a die grinder with a cut-off wheel
- Ohmmeter
- Wire cutters/strippers
- Wire crimping or soldering tools
- Blue thread locking compound

Lokar Shifters are designed to fit specific transmissions. Before you begin the installation, verify that you have the proper model for your transmission. If your Shifter does not seem to fit properly, do not make modifications during installation as this may void your warranty. Call for assistance.

Verify that the length of the Shifter you have purchased is what you actually want. When installed, the bottom of the shifter lever will be approximately 3-1/2" - 4" above the transmission case. From that point up to the top of the knob is how the shifter length is determined.

If you mount the shifter assembly all the way forward, using the four bolt holes at the very front of the main plate, a Bell Crank Kit (Lokar Part No. ATA-7101, sold separately) may be required.

Before attempting to make any adjustments, the Shifter must be installed on the transmission and the transmission should be installed to the vehicle.

The shifter lever is designed to lock in Park and in Neutral. You must depress the release button in the top of the shifter knob in order to shift out of Park or Neutral. The release button will only be flush with the top of the shifter knob when the shifter lever is in Park or Neutral.

To shift from Park directly to Drive, depress the release button and then hold it down while moving the shifter lever, and the shifter lever will automatically stop in the Drive position. Once you release the button, the shifter lever can be moved into 2nd gear. You must depress the release button again to shift down into 1st gear.

These instructions assume you have full access to the transmission when the installation is begun, with the transmission removed from the vehicle, or the vehicle body removed from the chassis.

TH350 Case Mount Shifter Installation Instructions

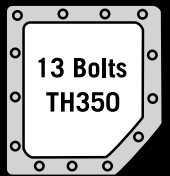

Building American Quality... With A Lifetime Warranty!®

TOLL FREE 1-877-469-7440 • tech@lokar.com • www.lokar.com

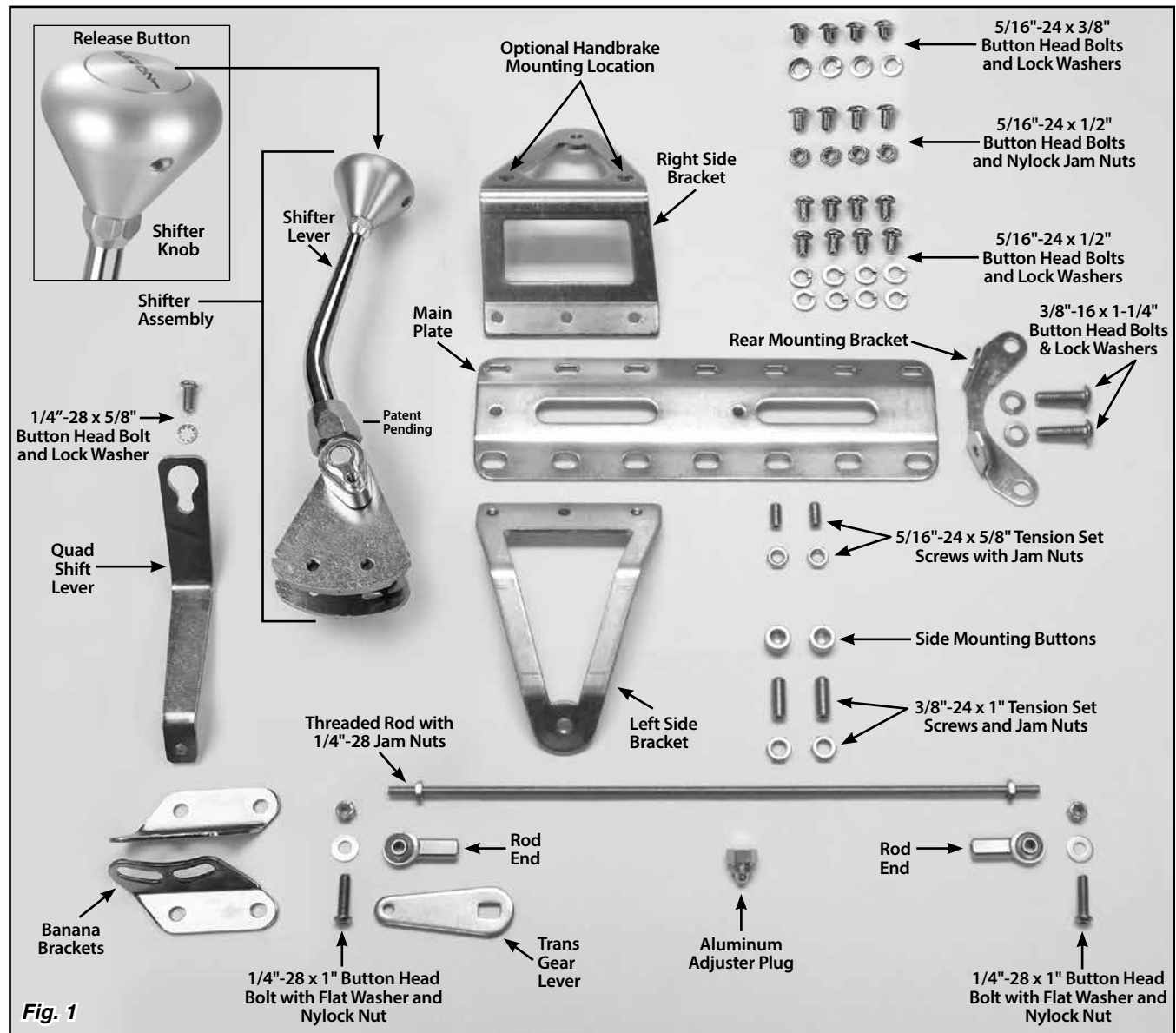
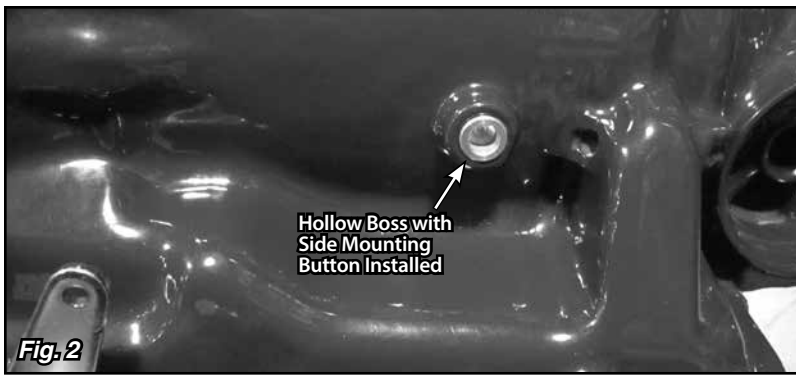

Fig. 1



Hollow Boss with Side Mounting Button Installed

Step 1: If your vehicle already has a shifter of any type installed, disconnect all shifter linkage and remove the shifter and its related hardware (neutral safety switch, back-up light switch, etc.).

Step 2: In the Lokar Shifter Kit you are supplied with two aluminum side mounting buttons approximately 5/8" in diameter. Your transmission has two round, hollow bosses cast into the case, one on the driver side and one on the passenger side. Clean any paint or debris out of these bosses, and install the side mounting buttons into the bosses with the flat side in toward the transmission case. **Fig. 2**

Step 3: The main plate has two 5/16"-24 tension set screw holes. One set screw hole is in the center of the main plate, and the other set screw hole is at one end of the main plate. The main plate will be installed so the end of the main plate that has a set screw hole will go to the front (towards the engine).

The left side bracket and right side bracket bolt directly to the main plate. Attach the side brackets to the underside of the main plate as shown in **Fig. 3**, using three 5/16"-24 x 1/2" button head bolts and lock washers on each side. **DO NOT TIGHTEN AT THIS TIME.**

NOTE: Some 4 wheel drive applications cannot use a rear mounting bracket. If the transfer case will not allow the rear mounting bracket to fit, skip **Step 4** and go on to **Step 5**.

Step 4: Attach the rear mounting bracket to the underside of the main plate with the bracket ears pointing to the rear of the transmission (toward the rear axle) as shown in **Fig. 3**, using two 5/16"-24 x 1/2" button head bolts and lock washers. **DO NOT TIGHTEN AT THIS TIME.**

Step 5: If you are using the rear mounting bracket, remove the top two tail housing bolts from the transmission. Install the mounting bracket assembly onto the transmission by first installing two 3/8"-16 x 1-1/4" button head bolts with lock washers through the rear mounting bracket and into the transmission at the tail housing. **Fig. 4** If you have a 4 wheel drive application that will not accept the rear mounting bracket, start the 5/16"-24 x 5/8" tension set screws into the tension set screw holes at the front and in the center of the shifter main plate. Set the mounting bracket assembly into place on top of the transmission. **Fig. 4**

Step 6: Install the 3/8"-24 x 1" tension set screws through the side brackets into each side mounting button, but do not tighten.

Step 7: Tighten all of the bolts on the left, right, and rear mounting brackets, leaving the tension set screws for last. Tighten the tension set screws on the side brackets until the side brackets move outwards about 1/8". On 4 wheel drive applications without the rear mounting bracket, tighten the set screws in the main plate last, threading them in until they contact the top of the transmission case (if you are using the rear mounting bracket you do not need set screws in the main plate). Finally, install a 3/8"-24 jam nut onto the tension set screws on the side brackets and tighten.

On 4 wheel drive applications not using the rear mounting bracket, install and tighten the 5/16"-24 jam nuts on the set screws in the main plate.

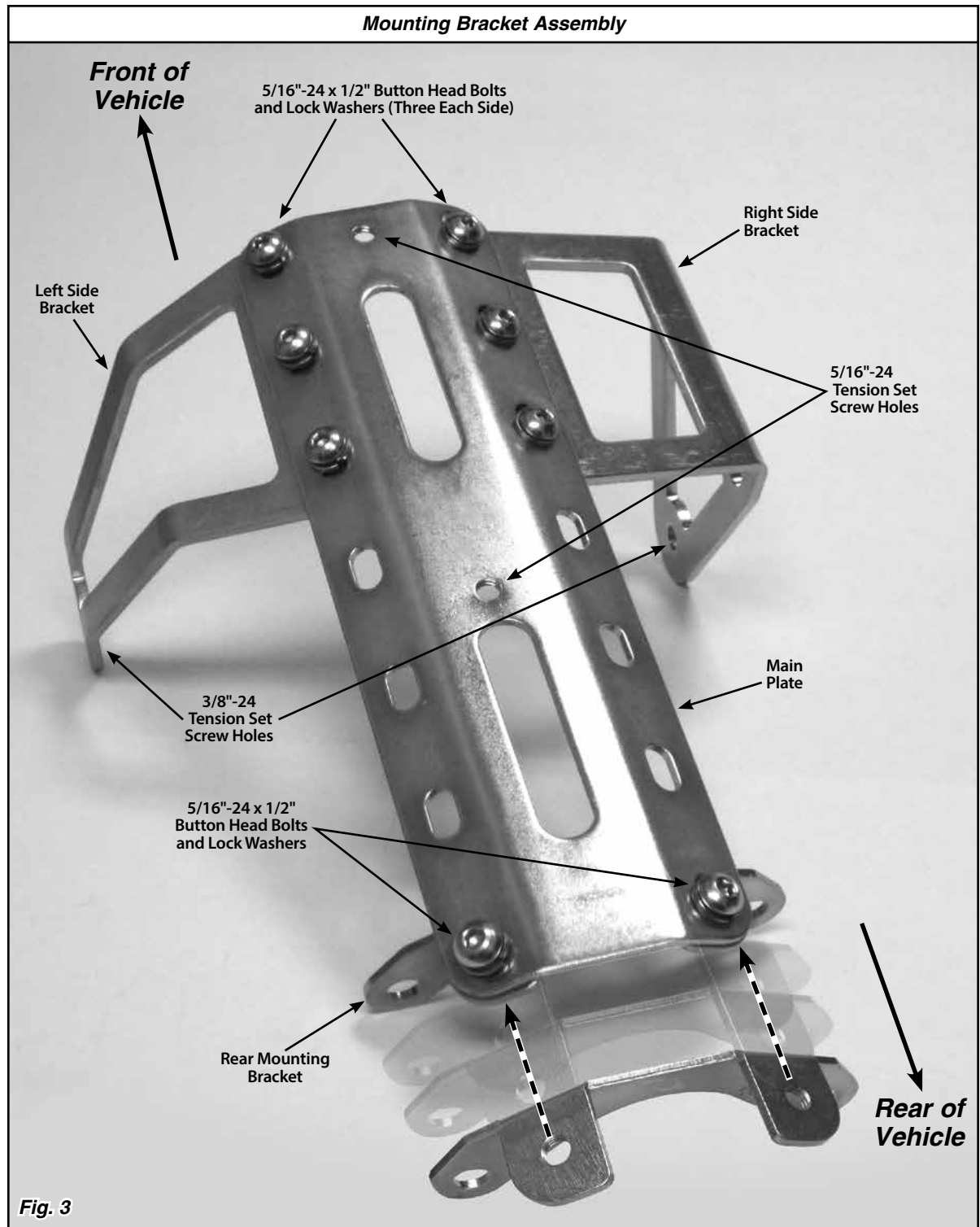

Fig. 3

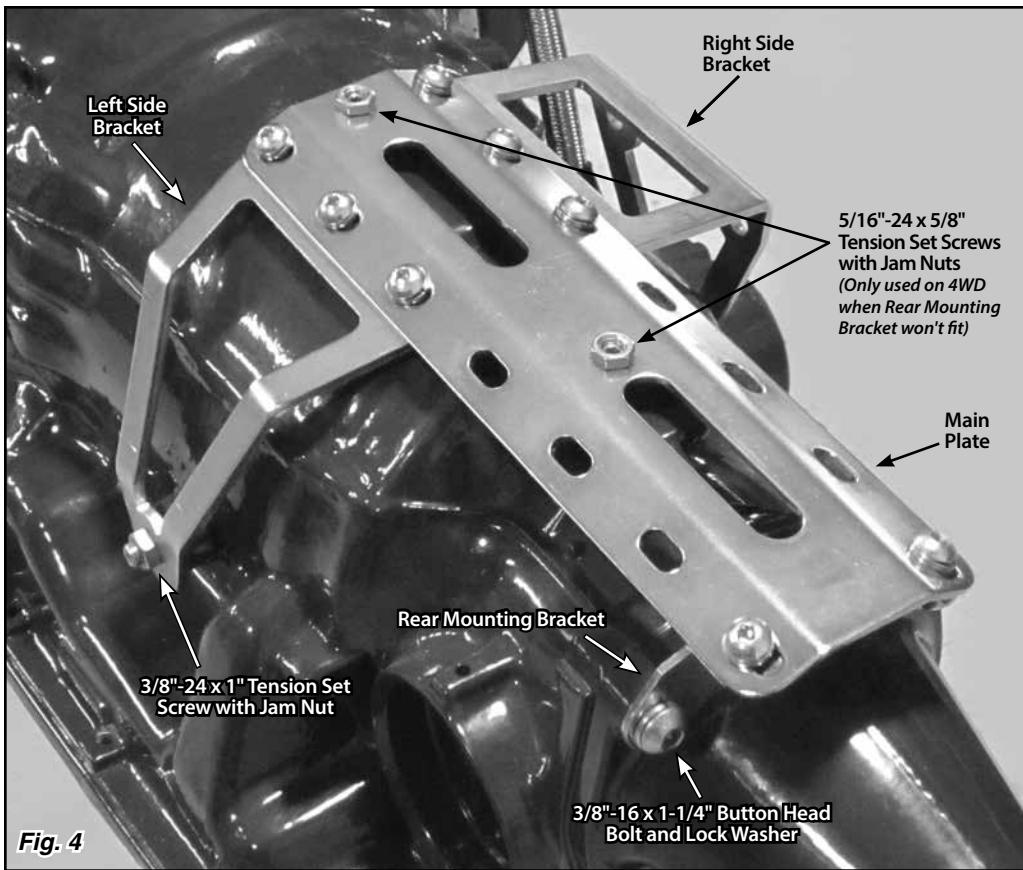

Fig. 4

Step 8: Install the banana brackets onto the shifter assembly using the 5/16"-24 x 3/8" button head bolts with lock washers. The curved, slotted holes in the banana brackets go against the shifter, and the bottom of both banana brackets should be pointing towards the rear.

Make sure you are using 3/8" long bolts. They will be the shortest bolts in the shifter kit. DO NOT use the 5/16"-24 x 1/2" button head bolts that came in the packet with the banana brackets to attach the banana brackets to the shifter! Those bolts will be used in the next step. Fig. 5

Step 9: You are now ready to position your shifter assembly onto the main plate. There are six mounting position options from front to rear on the transmission.

If your vehicle already has a shifter opening in the tunnel and the engine is installed in the vehicle, measure from the rear face of the engine block to the center of your existing shifter opening. If your engine is not yet installed in the vehicle, measure from the engine mounts to the center of the existing shifter opening instead.

If the vehicle does not have an existing shifter opening in the transmission tunnel, decide where you want the Shifter to be positioned so it will be comfortable and will not interfere with the dash or a bench seat (if applicable). Mark that spot on the tunnel, and measure as described above.

Transfer that measurement to the transmission (or to the engine/transmission assembly if the engine is not installed in the vehicle). Mark that location on the main plate. The holes in the main plate closest to your mark are where the **FRONT** banana bracket bolts will need to be installed. Fig. 6

If you choose to install the shifter assembly where any of its mounting holes line up with the left, right, or rear bracket mounting bolts, mount the shifter assembly using the same bolts and lock washers already being used to attach the left, right, or rear mounting brackets to the main plate. In this case, the bolts will go through the banana bracket first, then through the main plate, and finally into the mounting bracket below.

Any shifter mounting holes that do not line up with the side or rear mounting bracket bolts must use the provided 5/16"-24 x 1/2" button head bolts and nylock jam nuts (**NO lock washers**). Make sure the shifter assembly is mounted using all four bolt holes. **Do not use any other length bolts.**

NOTE: If mounting the Shifter all the way forward, using the four bolt holes at the very front of the main plate, a Bell Crank Kit (Lokar Part No. ATA-7101, sold separately) may be required. Fig. 6

Step 10: If your vehicle does not already have an existing shifter opening, cut the opening now. If you are using a Lokar Shifter Boot, the maximum opening for a Round Boot is 4" in diameter, and the maximum opening for a Rectangular Boot is 4" wide by 5-1/2" long.

Before proceeding any further, the transmission should be installed in the vehicle, with the vehicle body, seat and dashboard in place.

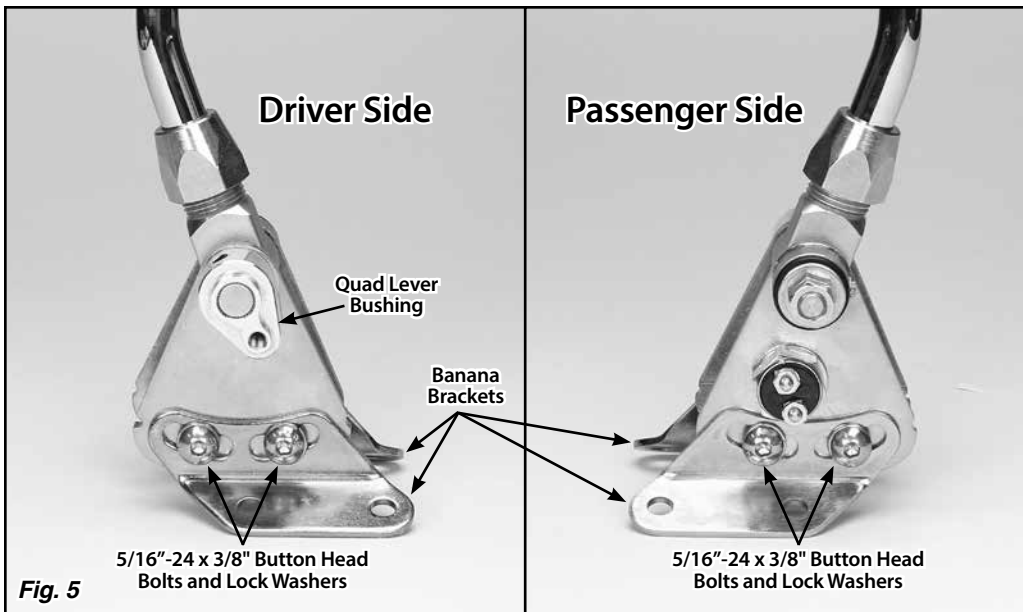

Fig. 5

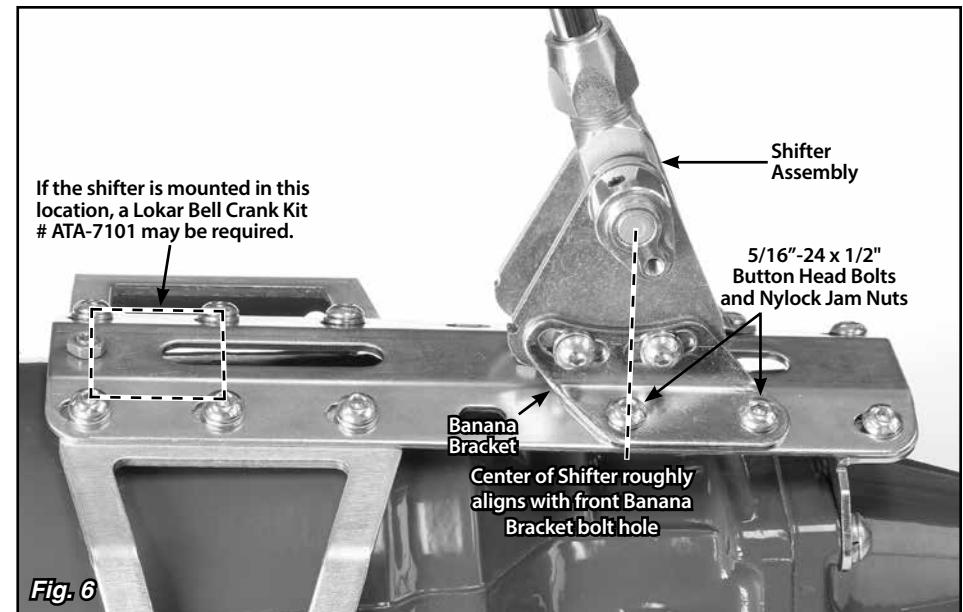
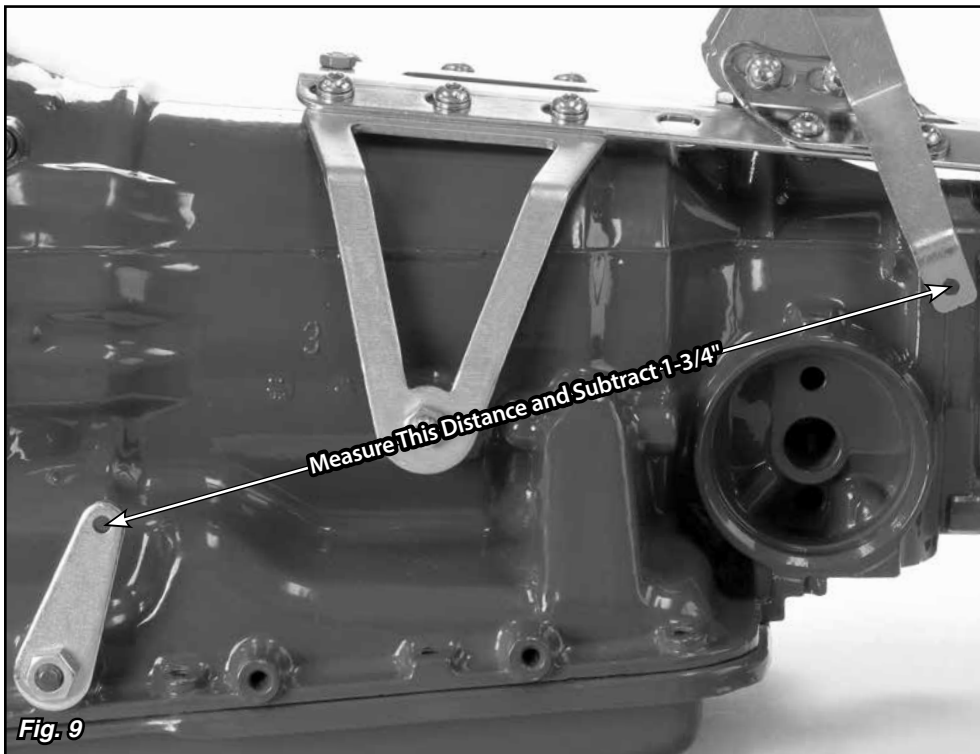
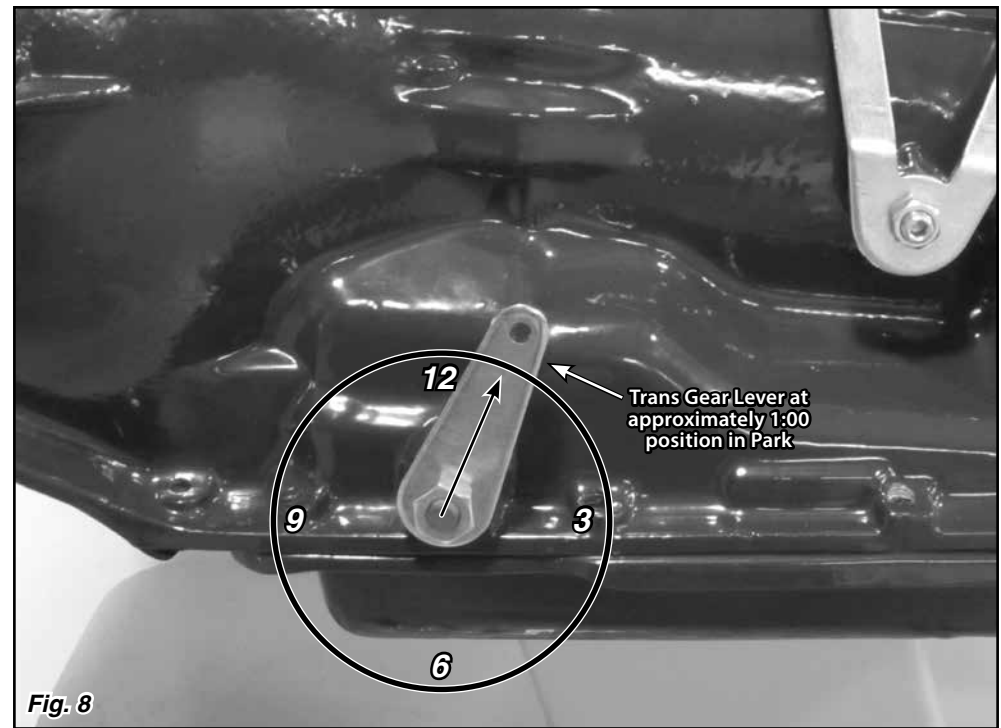
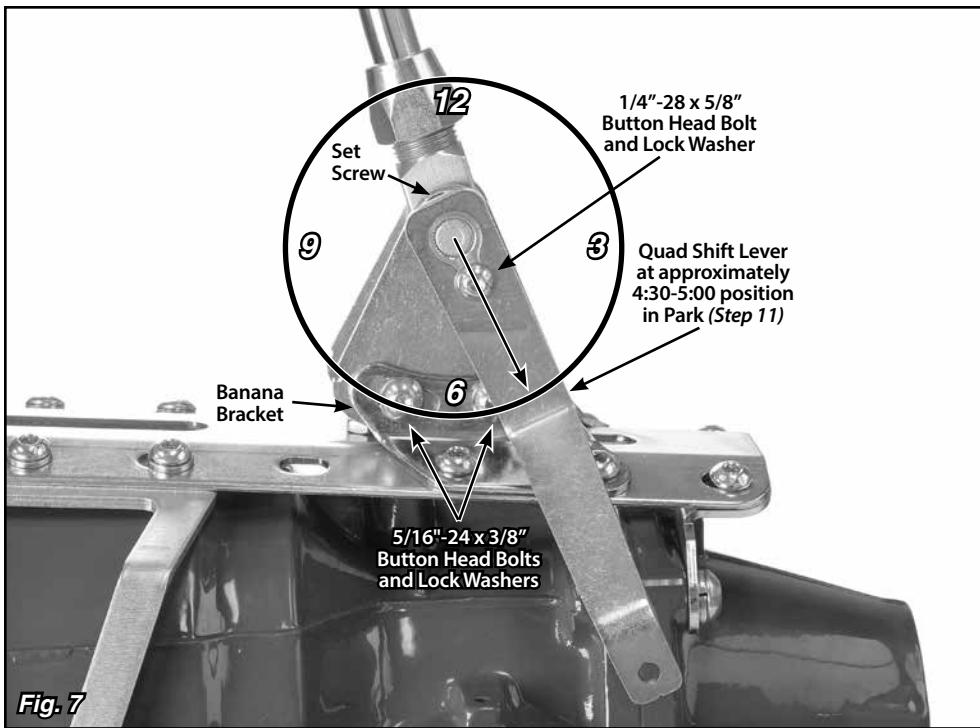

Fig. 6



Step 11: Make sure the two 5/16"-24 x 3/8" button head bolts and lock washers that attach the driver side banana bracket to the shifter assembly (in the curved, slotted holes) are tight using a 3/16" Allen wrench. Before tightening the shifter assembly down to the main plate, move the shifter lever through all the gear positions. Make sure the shifter lever and knob do not come in contact with the dash or the seat. The shifter assembly can be tilted forward or backward if needed by loosening the 5/16"-24 x 3/8" button head bolts and lock washers in the curved, slotted holes in the driver side banana bracket. **Fig. 7**

If you ever disassemble the shifter assembly, be sure the 5/16"-24 x 3/8" button head bolts and lock washers are put back into the curved, slotted holes in the banana brackets. Installing longer bolts will prevent the shifter from operating.

NOTE: After installation, if you find the shape or length of the shifter lever is not suitable for your application, Lokar has a number of different styles and lengths of Lever Conversion Kits available for purchase separately through our dealer network.

Once you have verified the shifter lever and knob do not come in contact with the seat or the dash, tighten the banana brackets down to the main plate.

Step 12: Make sure the shifter lever is in the Park position. Temporarily place the quad shift lever in position on the quad lever bushing as shown in **Fig. 7**. Check for interference with the vehicle floor. With the shifter lever in Park, you want the quad shift lever to be pointing towards approximately the 4:30 – 5:00 position.

If the quad shift lever is not pointing towards the 4:30 - 5:00 position, loosen the set screw in the top of the quad lever bushing using a 1/8" Allen wrench. Slide the quad lever bushing off of the shifter. Reinstall the bushing pointing towards approximately the 4:30 - 5:00 position as shown. Retighten the set screw, and check again for interference with the floor. Trim the floor if needed.

NOTE: If your shifter assembly is placed near the front of the main plate, you may need to position the quad shift lever slightly higher, such as pointing towards the 4:00 position instead. This will help prevent over-centering the trans gear lever.

With the quad shift lever in position on the quad lever bushing, install the 1/4"-28 x 5/8" button head bolt and lock washer into the bushing, and tighten with a 5/32" Allen wrench.

Step 13: Make sure the transmission is in Park by rotating the original trans gear lever clockwise as far as it will go. Remove the original nut and trans gear lever from the transmission selector shaft. Install the new trans gear lever onto the selector shaft, pointing up and slightly towards the rear, at approximately the 1:00 position.

Secure the new trans gear lever with your original nut. **Fig. 8**

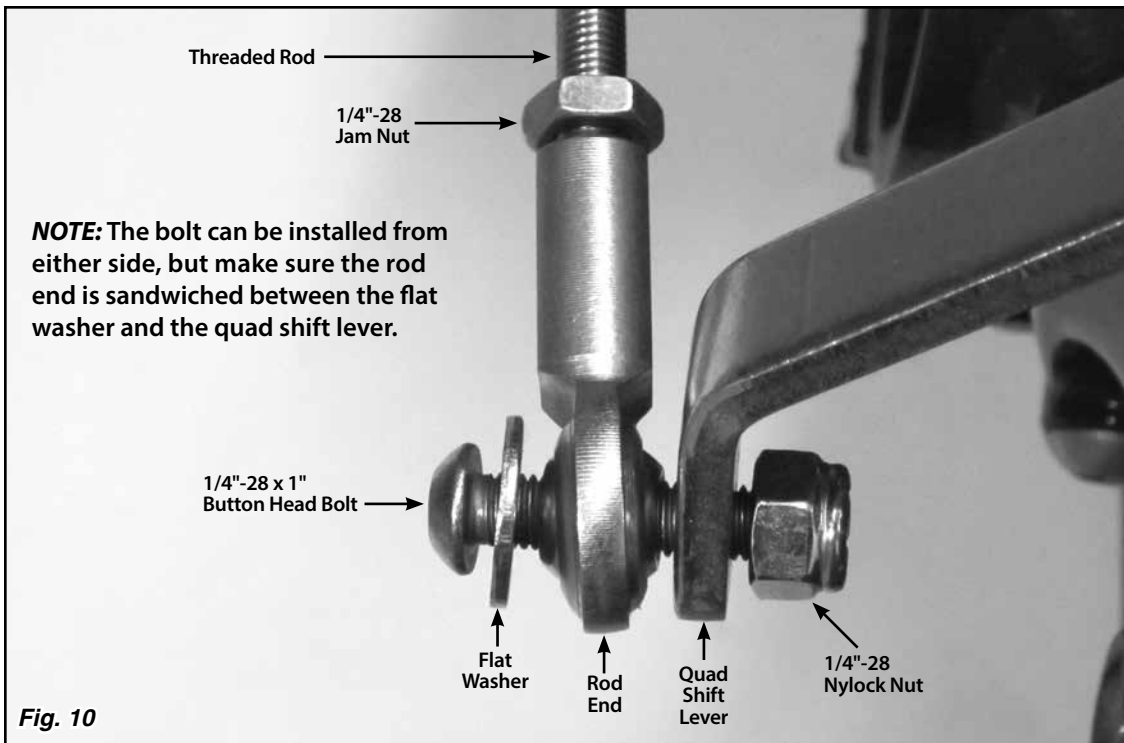

Fig. 10

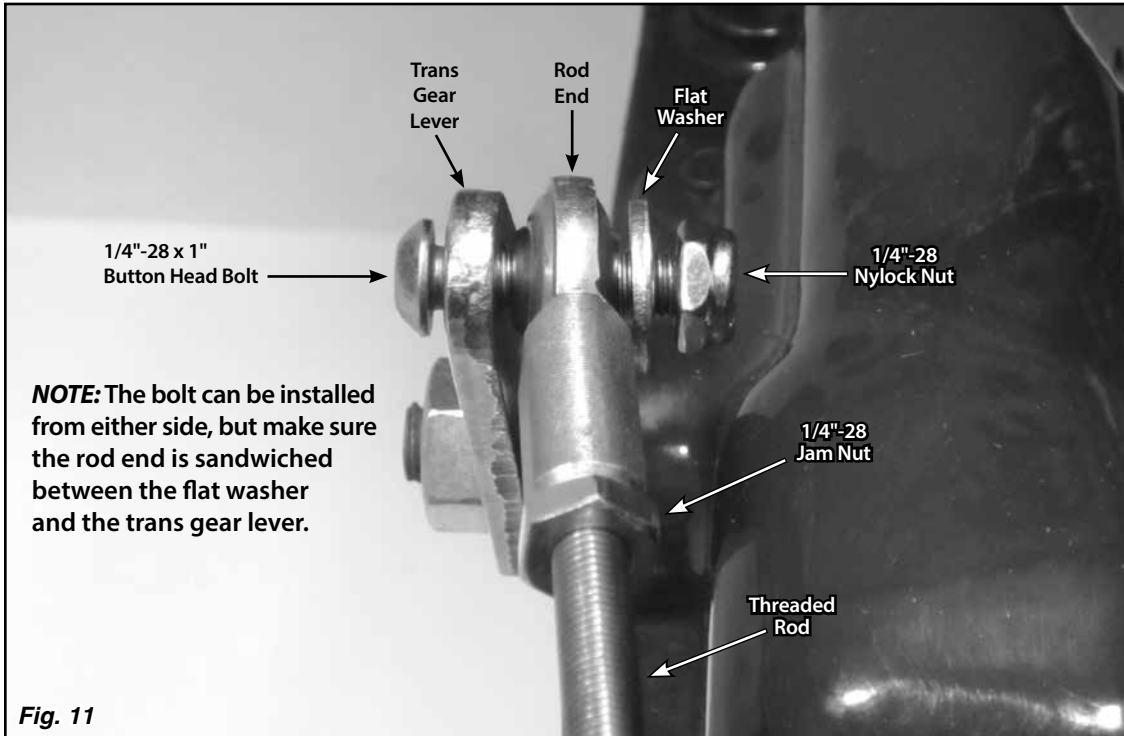

Fig. 11

Step 14: The threaded rod will connect the quad shift lever to the trans gear lever. Check to make sure nothing will interfere with the travel of the threaded rod. If there is any interference, **the threaded rod can be bent slightly as needed.**

Verify both the shifter lever and the transmission are in the Park position. Measure center-to-center between the 1/4" holes in the trans gear lever on the transmission and the quad shift lever on the shifter assembly. Subtract 1-3/4". **Fig. 9** This is the length you will cut the threaded rod to. Use a hacksaw or other metal-cutting saw to shorten the threaded rod. Then, deburr the cut end.

Step 15: Verify both 1/4"-28 jam nuts are on the threaded rod, and install a rod end onto each end of the threaded rod. Attach the threaded rod assembly to the **inside** of the trans gear lever and to the **outside** of the quad shift lever using the 1/4"-28 x 1" button head bolts, flat washers, and nylock nuts as shown in **Fig. 10** and **Fig. 11**. The button head bolts can be installed from either direction, but make sure each rod end is sandwiched between the flat washer and the trans gear lever or quad shift lever.

Step 16: Check the adjustment of the shifter linkage by placing the shifter lever all the way forward into the Park position. Make sure the release button still moves up and down freely. The release button should be flush with the top of the shifter knob in Park and Neutral. In the Reverse position, you cannot pull the lever back into Neutral without depressing the release button.

While the shifter lever is in the Park position, make sure the transmission is firmly in the Park detent, with no tension on the threaded rod. You can verify this by using a 5/32" Allen wrench to remove the 1/4"-28 x 1" button head bolt with nylock nut that attaches the rod end to the quad shift lever or trans gear lever at either end of the threaded rod. Make sure the hole in the rod end exactly aligns with the hole in the quad shift lever or trans gear lever. The bolt should pass freely through both holes at the same time without binding. Do not force the holes to line up.

If the holes are not aligned, screw the rod end in or out just enough to be able to slide the bolt in and out without putting tension on the threaded rod. Make sure the quad shift lever and trans gear lever do not move during the adjustment procedure. Use this adjustment routine until the bolt will pass freely in and out of both the rod end and the quad shift lever or trans gear lever. Reinstall the 1/4"-28 nylock nut and the flat washer onto the bolt and tighten using a 5/32" Allen wrench.

Once you have the shifter linkage adjusted correctly, tighten the jam nuts on the threaded rod.

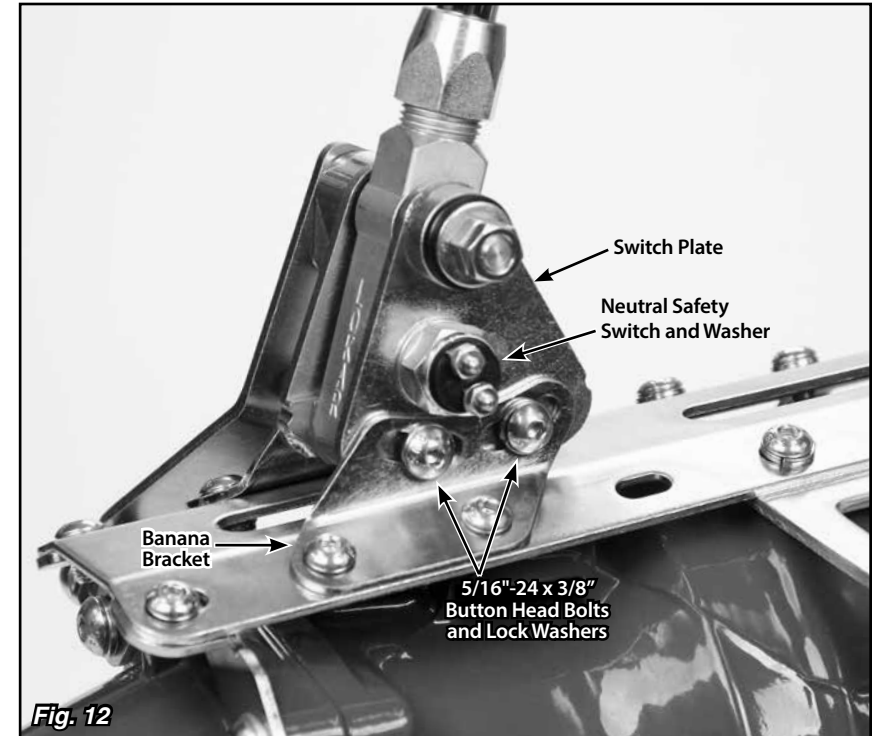

Fig. 12

Neutral Safety Switch Adjustment and Wiring

Step 17: For the neutral safety switch to function properly, the shifter linkage must be adjusted correctly. Do not attempt to adjust the neutral safety switch unless you have completed **Step 16**.

The Lokar neutral safety switch is a simple on/off, non-directional switch. The switch passes current (turns on) when the ball is pushed in. It does not pass current (turns off) when the ball is out at its at-rest position.

Double check to make sure the bolts connecting the driver side banana bracket to the shifter assembly are tight. **Fig. 5**

Step 18: Remove the neutral safety switch and washer from the switch plate on the passenger side of the shifter assembly using a 7/8" wrench or socket. **Fig. 12**

Step 19: Loosen, but do not remove, the two 5/16"-24 x 3/8" button head bolts and lock washers that attach the switch plate to the passenger side banana bracket (the bolts are in curved, slotted holes) using a 3/16" Allen wrench. **Fig. 12**

WARNING: Before taking the shifter lever out of Park, be sure the vehicle's tires are blocked and the parking brake is set to avoid movement of the vehicle.

Step 20: Put the shifter lever into the Reverse position. Reposition the switch plate so the hole in the switch plate lines up with the center groove in the shifter body. **Fig. 13** Screw the provided aluminum adjuster plug into the neutral safety switch opening. Wiggling the switch plate slightly forward and back while you are screwing the aluminum adjuster plug in will help get the shifter body centered on the adjuster plug. **Fig. 14**

Step 21: Retighten the two 5/16"-24 x 3/8" button head bolts and lock washers that attach the passenger side banana bracket to the switch plate using a 3/16" Allen wrench.

Step 22: Remove the aluminum adjuster plug, and reinstall the neutral safety switch and washer onto the shifter. Test for continuity by connecting an ohmmeter lead to each stud on the neutral safety switch. When adjusted correctly, you will only have continuity between the two switch studs when the shifter lever is in Park or Neutral. Continuity in any other gear requires readjustment of the neutral safety switch or the threaded rod.

Step 23: Connect the neutral safety switch between your ignition switch and starter circuits. Check the wiring of your fuse panel:

- **If there are (2) connections for a neutral safety switch**, run a #12 (or heavier) stranded wire from these terminals in your fuse panel to the (2) terminals on the neutral safety switch. That completes the Neutral Safety Switch wiring.
- **If your fuse panel does not have neutral safety switch connections**, locate the wire going from the ignition switch to the starter. If GM color codes are used, this wire will usually be purple. After locating the wire, disconnect it from the starter. It must be cut and routed from the ignition switch to one of the neutral safety switch terminals, and from the other neutral safety switch terminal to the same stud on the starter where the original wire was removed. If the wire must be lengthened, be sure to use wire at least the same size or larger than the original.

Step 24: Reconnect the negative battery cable and check operation. Make sure the engine will not start in reverse or a drive gear. If it does, follow the neutral safety switch adjustment procedure again. If your vehicle should ever start in any gear other than Park or Neutral, please readjust the neutral safety switch accordingly. Tighten all brackets and bolts correctly and securely and there should be no movement or maladjustment. If you have any questions after following this procedure, please call Lokar Technical Support.

Step 25: Once the installation is completely finished and the neutral safety switch is adjusted, remove each of the 5/16"-24 x 3/8" button head bolts and lock washers from the banana brackets one at a time, apply blue thread locking compound to the threads, and reinstall the bolts and lock washers.

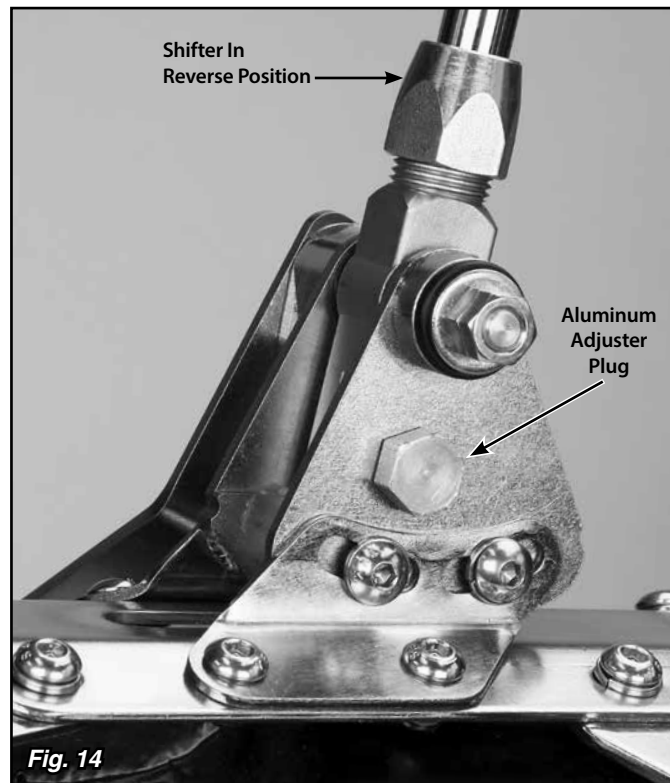
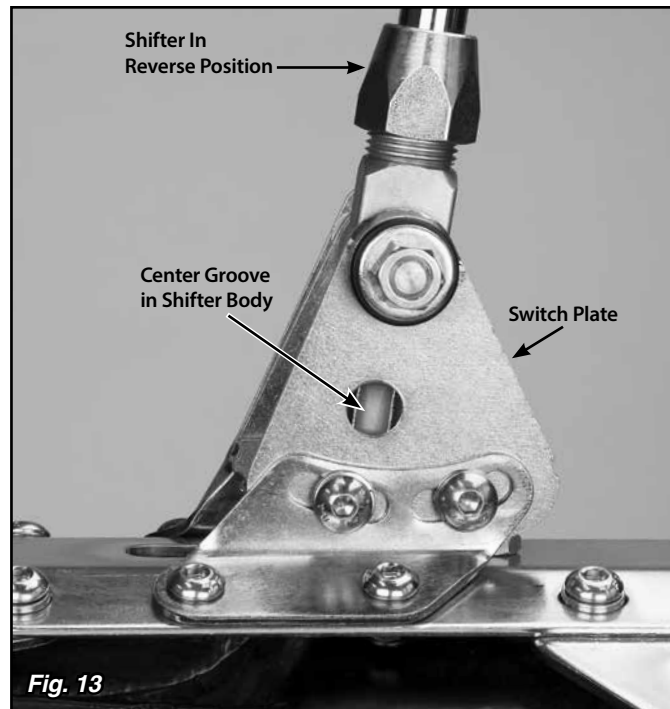

Lokar Shifter Knob Removal Instructions (For Shifters Manufactured 1995 and Later)

For Shifters manufactured 1994 and earlier, please contact Lokar for assistance.

To Remove Shifter Knob:

Step 1: Make sure the Shifter is all the way forward in Park.

Step 2: Loosen the jam nut below the shifter knob. **DO NOT** loosen or remove the set screw in the knob. **Fig. 15**

Step 3: Turn the shifter knob counter-clockwise to remove.

To Install Shifter Knob:

Step 1: Make sure the jam nut is still in place on the shifter lever.

Step 2: Screw the shifter knob onto the shifter lever until the release button comes up flush with the top of the shifter knob.

Step 3: Tighten the jam nut up against the bottom of the shifter knob.

Step 4: Check to make sure depressing the release button allows the shifter lever to be moved, and make sure the shifter lever still locks in Park and Neutral. If the shifter will not come out of "Park" with the release button fully depressed, tighten the knob one turn and check it again. If the shifter does not lock in "Park", loosen the knob one turn and check it again.

