



QUALITY... PLAIN & SIMPLE®

Goolsby Edge™ Edition Billet Aluminum Throttle Pedal Installation Instructions

Building American Quality... With A Lifetime Warranty!®

TOLL FREE 1-877-469-7440 • tech@lokar.com • www.lokar.com

Goolsby Edge™ Edition Billet Aluminum Throttle Pedal Installation Instructions

General Installation Notes:

Please read these instructions completely before beginning the installation. If you have any questions please call.

Before beginning the installation, disconnect the negative battery cable and use wheel chocks to block the vehicle's wheels.

We recommend using anti-seize lubricant on all aluminum threads.

IMPORTANT APPLICATION INFORMATION: The Goolsby Throttle Pedal is designed for use with a Lokar Throttle Cable. Stock style throttle cables will not work. If your vehicle has an automatic transmission, installation of a Lokar Kickdown Kit (if applicable) is strongly recommended. Lokar Throttle Cables and Kickdown Kits are application-specific according to the type of induction system and the transmission model.

Refer to Fig. 1 for the component names.

Step 1: Remove any existing throttle pedal assembly and linkage components.

Step 2: Determine your desired mounting location. If needed for clearance or alignment purposes, the upper and lower pedal arms can be switched left and right while the pedal is disassembled.

Step 3: Disassemble the throttle pedal assembly by removing the #10-32 x 3/8" flat head screw and aluminum end washer from either end of the pedal axle. You will need two 1/8" Allen wrenches (not included). One will be used to keep the pedal axle from spinning while you use the second one to remove the screw from the opposite end. **Fig. 2** Pull the pedal axle out of the pedal cradle.

Step 4: Remove the Delrin® bushing and the upper pedal arm from the splined bushing. If the upper pedal arm needs to be switched to the opposite side of the lower pedal arm for clearance or alignment purposes, push the splined bushing over so that it protrudes from the opposite side of the lower pedal arm, and remove the other Delrin® bushing from the splined bushing.

Reinstall the upper pedal arm and Delrin® bushing(s) onto the splined bushing with the upper pedal arm pointed up at the desired angle, so that the upper pedal arm will be parallel to the firewall with the throttle pedal at rest. **Fig. 3**

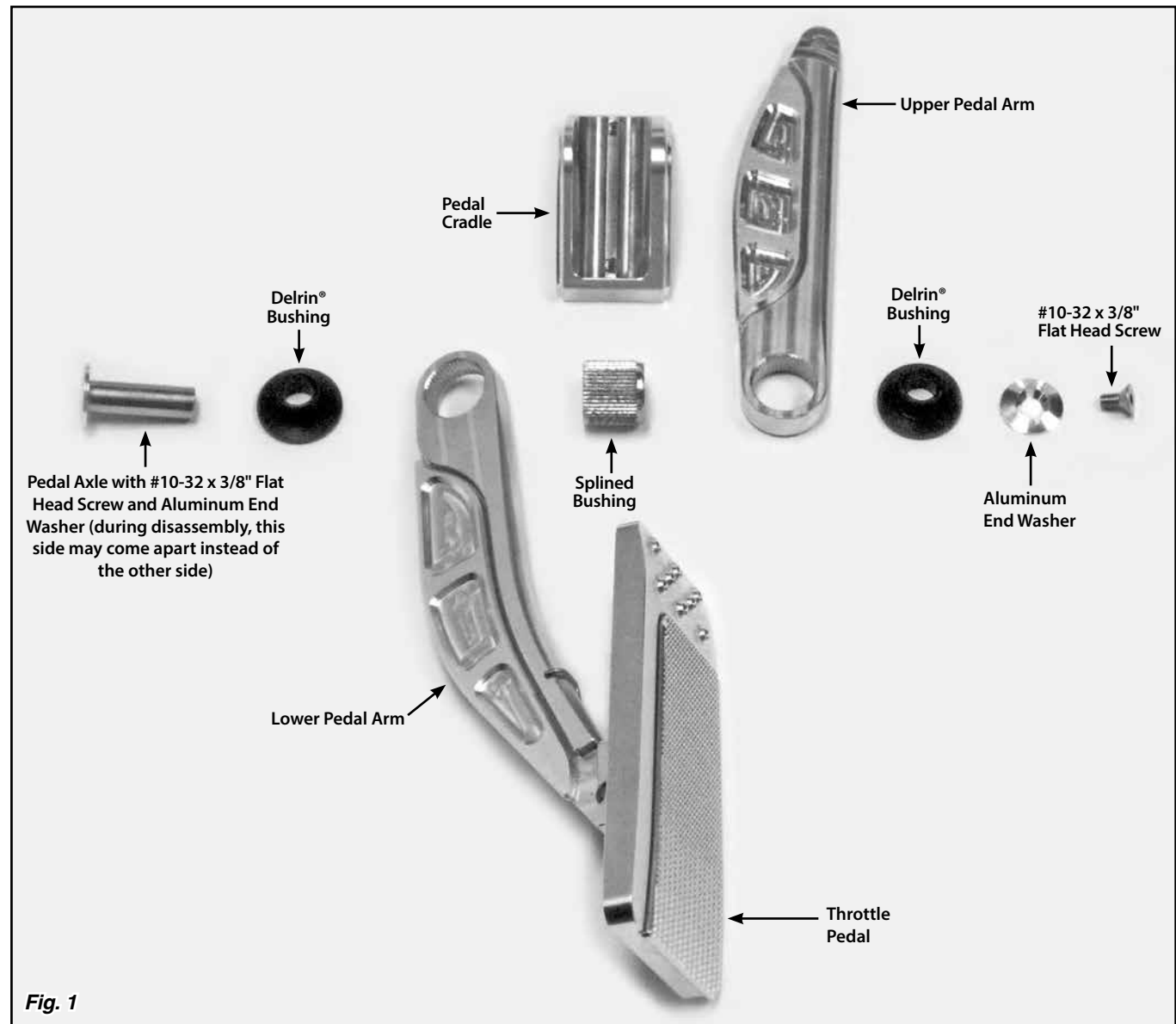

Fig. 1

Goalsby Edge™ Edition Billet Aluminum Throttle Pedal Installation Instructions

Step 5: Position the upper and lower pedal arms in the pedal cradle. Install the pedal axle through one side of the pedal cradle, through the splined bushing, and out the opposite side of the pedal cradle. Reinstall the #10-32 x 3/8" flat head screw and aluminum end washer onto the end of the pedal axle and tighten. Check the throttle pedal and make sure that the pedal is not binding.

Step 6: Position the throttle pedal assembly on the firewall in the desired location. Check to make sure that the throttle pedal will travel far enough to get the full range of throttle movement without interfering with anything under the dash. Shift the position of the throttle pedal assembly or change the angle of the upper pedal arm as required.

Once you have the throttle pedal assembly positioned correctly, mark the outline of the pedal cradle on the firewall. Then push the upper pedal arm forward against the firewall. Mark the firewall in line with the 3/16" hole on the end of the upper pedal arm.

Step 7: Remove the upper and lower pedal arms from the pedal cradle again as described in **Step 3** above. Position the pedal cradle on the firewall and use the pedal cradle as a template to mark the locations of the two mounting bolt holes.

Center punch the marks, and drill two 1/4" diameter holes in the firewall for the mounting bolts. Then center punch the mark you made at the top of the upper pedal arm, and drill a 5/16" hole for the throttle cable firewall fitting.

Step 8: Position the pedal cradle onto the firewall and install two 1/4"-20 bolts (not included) from the engine compartment through the firewall and into the pedal cradle. **Fig. 4** Make sure the bolts are not long enough to interfere with the movement of the upper or lower pedal arms.

Step 9: Reinstall the throttle pedal assembly into the pedal cradle as described in **Step 5** above. Install the Lokar Throttle Cable, following the instructions that are supplied with the Throttle Cable Kit. **Fig. 5**

Note: Adjust the Throttle Pedal and Throttle Cable so that the pedal touches the floor at the same time the throttle reaches wide open position. This will ensure that you will not over pull the throttle.

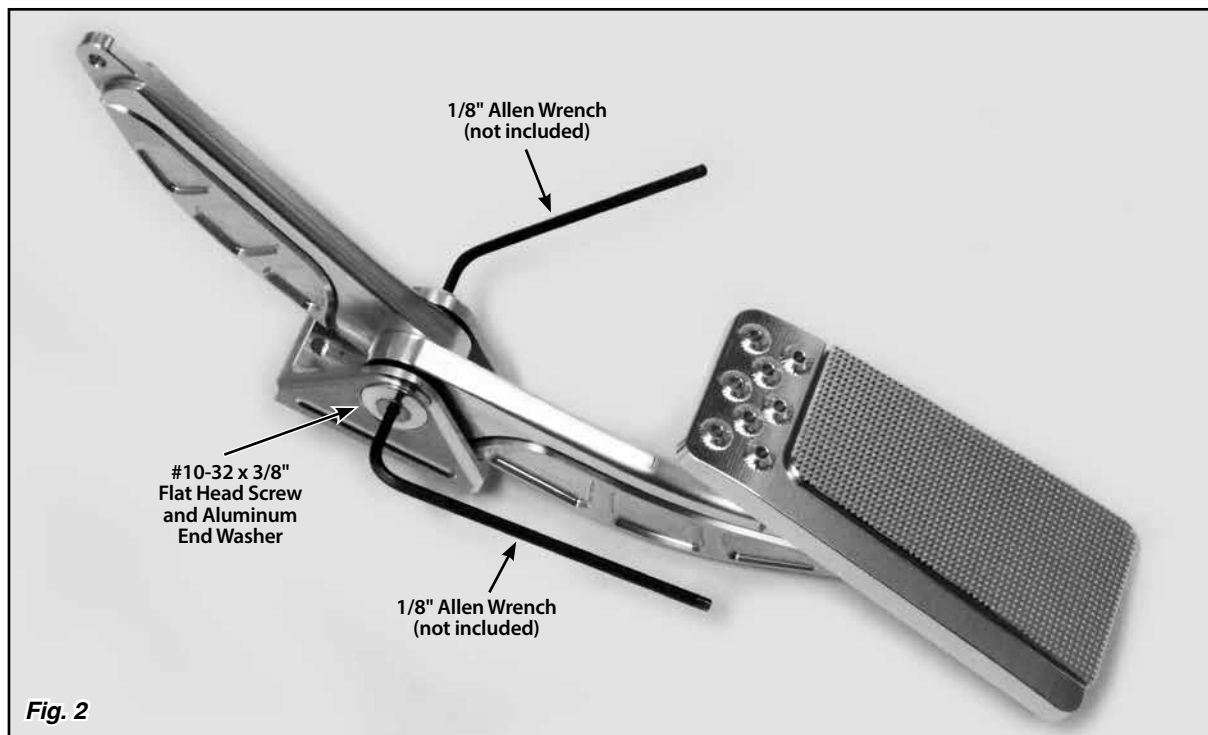

Fig. 2

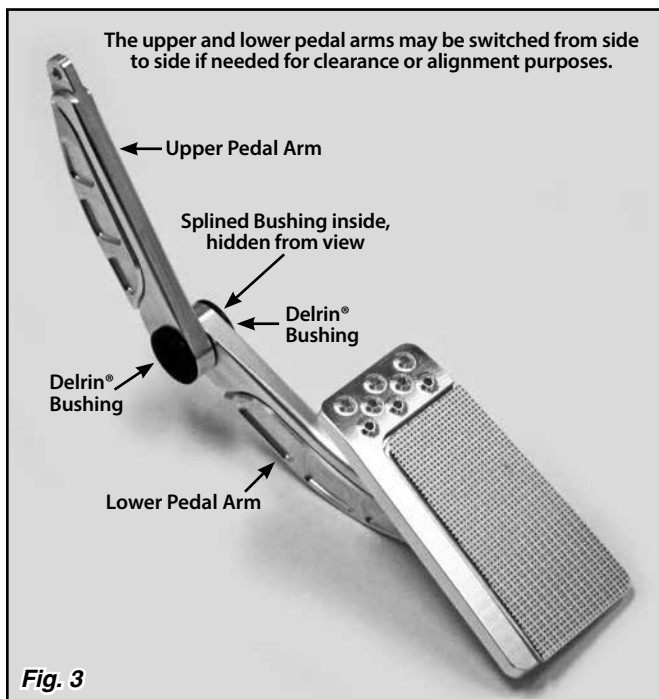

Fig. 3

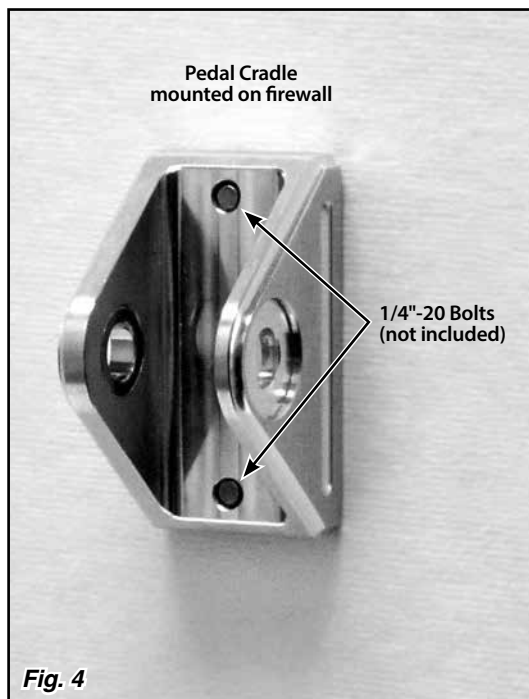

Fig. 4

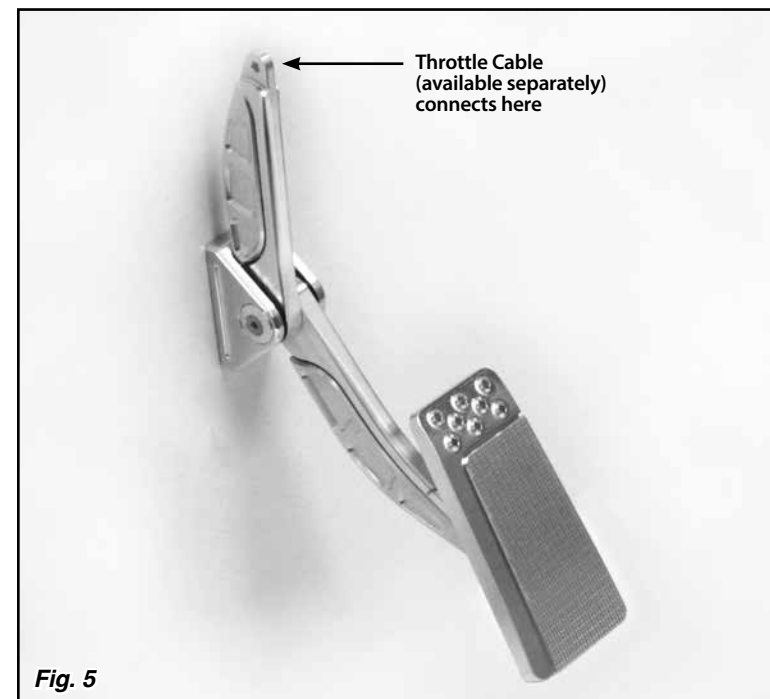

Fig. 5