

# LS Classic Series By Lokar 14" Classic Air Cleaner Installation Instructions

Building American Quality... With A Lifetime Warranty!®

TOLL FREE 1-877-469-7440 • tech@lokar.com • www.lokar.com

## LS Classic Series By Lokar 14" Classic Air Cleaner Installation Instructions

### General Installation Notes:

Please read these instructions completely before beginning the installation. If you have any questions, please call.

Before beginning the installation, disconnect the negative battery cable and use wheel chocks to block the vehicle's wheels.

We recommend using anti-seize lubricant on all aluminum threads.

All product installation instructions can be found by visiting [www.lokar.com/instructions.html](http://www.lokar.com/instructions.html).

Refer to Fig. 1 for the component names.

**NOTE:** The throttle body adapter must be installed with its recessed edge on the same side as the throttle body electronics. If you are using the LS Classic Simulated Distributor, the throttle body must be installed with the electronics towards the front of the engine. If you are not using the Simulated Distributor, the throttle body can be installed facing either direction, but the recessed edge of the throttle body adapter must still be on the same side as the throttle body electronics.

**Step 1:** Place the provided throttle body gasket and throttle body adapter onto your intake manifold, with the O-ring groove in the adapter on the top side, and the recessed edge of the throttle body adapter in the appropriate position as described above. Install the four 5/16"-18 x 1" hex head bolts into the corners of the throttle body spacer, and tighten. **Fig. 2**

**Step 2:** Place the throttle body O-ring into the groove on the top of the throttle body adapter. **Fig. 2** Position your throttle body (not included) onto the throttle body adapter, with the throttle body electronics on the same side as the recess in the throttle body adapter.

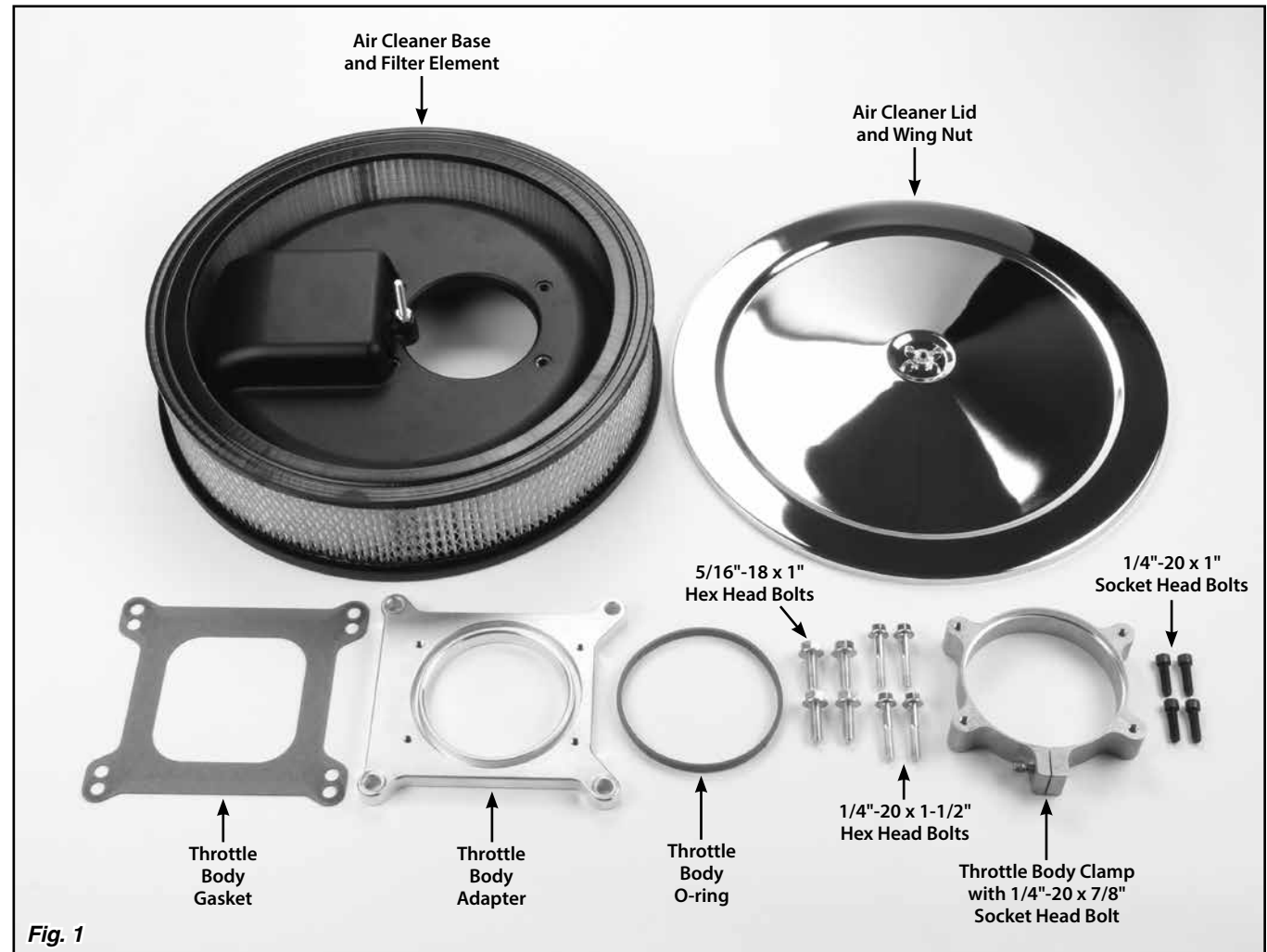
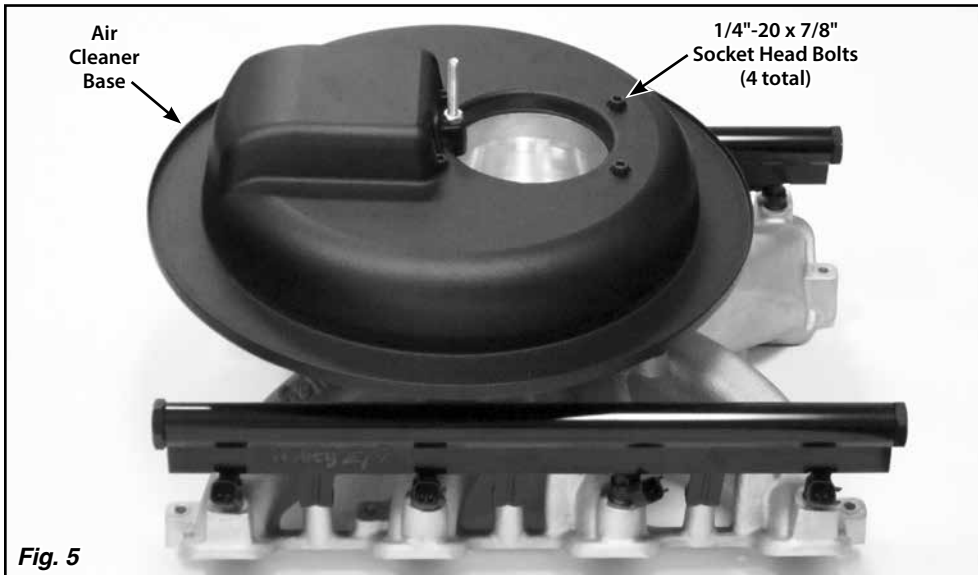
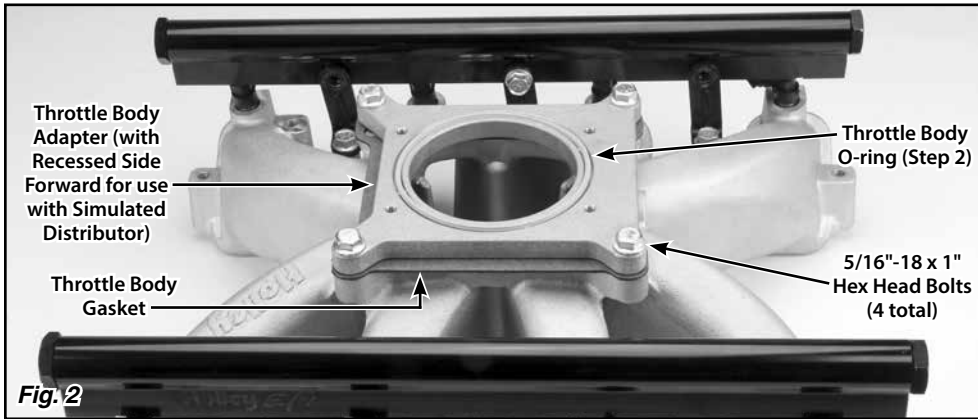

Fig. 1

**Step 3:** Install the four 1/4"-20 x 1-1/2" hex head bolts in the corners of your throttle body, and tighten. **Fig. 3**

## LS Classic Series By Lokar 14" Classic Air Cleaner Installation Instructions



**Step 4:** Note the inside of the throttle body clamp has a recess around one edge. The throttle body clamp will be installed with that recess on the top. Remove the 1/4"-20 x 7/8" socket head bolt from the throttle body clamp. Spread the throttle body clamp enough so it will slide over the throttle body. Push it down so the bottom of the throttle body clamp sits flush against the throttle body, and the lip at the top of the throttle body fits into the recess in the top edge of the throttle body clamp.

Reinstall and tighten the 1/4"-20 x 7/8" socket head bolt in the throttle body clamp using a 5/32" Allen wrench. **Fig. 4**

**Step 5:** Place the air cleaner base onto the throttle body clamp. Install the four 1/4"-20 x 1" socket head bolts to attach the air cleaner base to the throttle body clamp, and tighten using a 5/32" Allen wrench. **Fig. 5**

**Step 6:** Place the air cleaner filter element onto the air cleaner base, making sure the filter element is fully seated onto the air cleaner base. Place the air cleaner lid onto the filter element, and install the air cleaner wing nut finger-tight. **Fig. 6**

